

UpRight SL20

self propelled

narrow electric vertical lift



8.1m working height

340kg platform capacity

Roll-out deck extension
provides greater platform area
and over-reach facility

Smooth, one-hand,
proportional controls

Driveable with
platform fully elevated

Passes through
standard doorways

Non-marking tyres

Quick access to
service components

Five year structural
warranty

CE approved

specifications	SL20
working height (A)	8.10m
platform height (B)	6.10m
platform capacity (max.)	340kg
platform size (inside)	0.74m x 2.53m
-with deck extended	0.74m x 3.31m
weight	1411kg
drive height (max.)	6.10m
entry height (C)	1.04m
stowed height (D)	2.1m
length - deck retracted (E)	2.75m
length - deck extended	3.53m
width (F)	0.84m
drive speed (max.)	3.70 km/h
- with platform raised	1.0 km/h
gradeability	25%
inside turning radius	0.64m
outside turning radius	2.52m
ground clearance	100mm
lift speed - raise/lower	14 seconds
toe boards	150mm
control system	one-hand proportional control
power source	24V battery pack (4-220 A hour, 6V batteries) 4 HP DC electric motor
battery charger	25 amp
non-marking tyres	381mm diameter solid rubber, non-marking
parking brake	dual-spring applied, hydraulically released

Specifications subject to change without notice. Photos and diagrams in this brochure are for promotional purposes only. Refer to appropriate UpRight Operators manual for detailed instructions on the proper use and maintenance of this equipment. The SL20 meets or exceeds all applicable CE and GS machinery directive requirements.

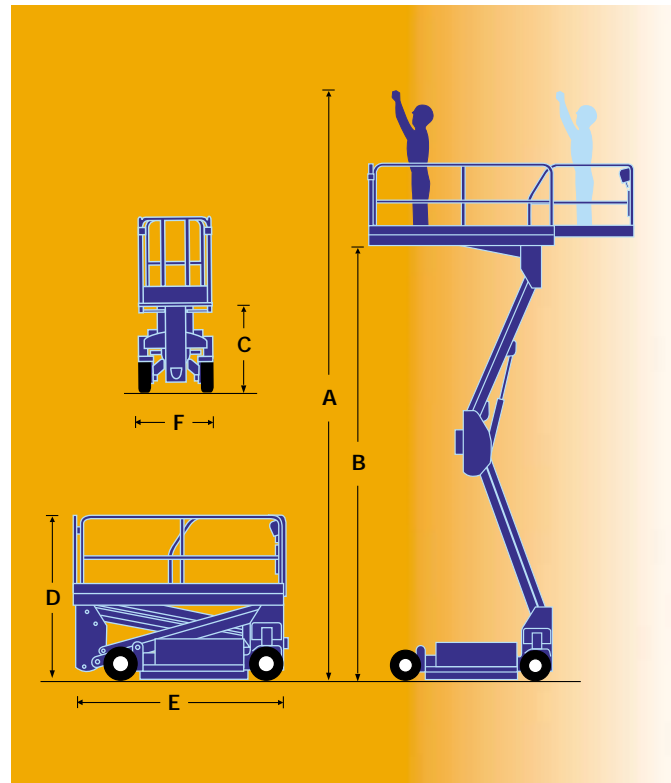

Hydraulic depression mechanism system activates when platform is elevated.



High angle steering for excellent manoeuvrability.

standard features

Selectable motion alarm
Dual front wheel direct drive
Integral cushion down
Hydraulic depression mechanism
Crane lifting points
Hour meter / low voltage indicator
Heavy-duty, round guardrails
Rear break hubs
Tilt alarm, c/w cut out
Overload sensor

Horn, push button on controller
Treaded non-marking tyres
Platform material loading system
Non-slip platform

options

Power to the platform
Flashing amber beacon
Air line to platform
Special paint colours
2/3 year warranty

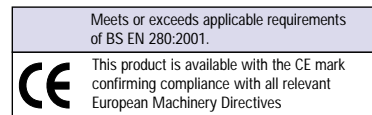

Meets or exceeds applicable requirements of BS EN 280:2001.

This product is available with the CE mark confirming compliance with all relevant European Machinery Directives

manufactured by

UpRight

UpRight

www.upright.com
e-mail: marketing@upright.com

GLOBAL PROVIDER OF ACCESS SOLUTIONS

MANUFACTURING

North America
Tel +1 (559) 662 3900
Fax +1 (559) 673 6184

Europe
Tel + 353 1 620 9300
Fax + 353 1 620 9301

SALES

USA / The Americas
Tel +1 (559) 662 3900
Fax +1 (559) 673 6184

Europe/Africa/M. East
Tel + 44 (0) 1952 685 200
Fax + 44 (0) 1952 685 255

France
Tel + 33 130 37 05 44
Fax + 33 130 37 63 68

Germany
Tel + 49 2103 98950
Fax + 49 2103 989549

Singapore
Tel + 65 6324 1322
Fax + 65 6225 5157

Australia
Tel + 61 2 9748 6200
Fax + 61 2 9748 6255

P. R. China
Tel + 86 21 63390190
Fax + 86 21 63390191

Japan
Tel + 81 3 5765 6841
Fax + 81 3 5765 6840

