

UpRight
TL38/49

trailer mounted
boom lifts

Working heights
up to 55ft.(17m.)

Working Outreach
to 27ft. 3in.(8.3m.)

Two person platform - up to
475lbs.(215kg.) capacity

Fast set-up time with
manual Quickset™ or
hydraulic outriggers

Compact travel dimensions
make towing easy

Optional drive-assist
(TL49) gives greater
manoeuvrability

5 year structural warranty



Photograph shown CE. model

specifications	TL38	TL49
Working height	43ft. 9in. (13.5m.)	55ft. 3in. (17.0m.)
Platform height	37ft. 9in. (11.5m.)	49ft. 3in. (15.0m.)
Max. working height at full outreach -	20ft. (6.1m.)	27ft. 3in. (8.3m.)
Horizontal outreach	18ft. 4in. (5.6m.)	25ft. 7in. (7.8m.)
Jib length	4ft. (1.2m.)	n/a
Platform capacity	475lbs. (215kg.)	475lbs. (215kg.)
Platform size (inside guardrails)	24in. x 48in. (0.6m. x 1.2m.)	24in. x 48in. (0.6m. x 1.2m.)
Rotation (non-continuous)	370 degrees	370 degrees
Max. number of occupants	2	2
Travel dimensions		
Width A	5ft. (1.52m.)	5ft. 3in. (1.60m.)
Length B	19ft. 7in. (5.97m.)	19ft. 7in. (5.97m.)
Height C	6ft. 6in. (1.99m.)	6ft. 6in. (1.99m.)
Manual outriggers	Quickset™ with screw jack level adjusters. Electric interlocks prevent boom operation until all outriggers are taking load.	n/a
Hydraulic outriggers	Hydraulically-operated with check lock valves and interlock system, preventing operation until all outriggers are taking load.	
Outrigger footprint	10ft. 10in. (3.3m.)	13ft. 1in. (3.98m.)
Power source	24V DC, 4 x 6V 220 Ah batteries	
Control system	One-hand proportional joystick operating energy efficient motor control system.	
Tires	185R13C 6 ply radials	195R14 tires
Braking	Automatic reverse and overrun brakes plus handbrake	
Weight with Hydraulic outriggers	3,278lbs. (1,490kg.)	4,189lbs. (1,900kg.)
Weight with Manual outriggers	3,234lbs. (1,470kg.)	n/a

* Working height in the U.S. is 6ft. above platform height. Metric working height is 2m. above platform height. Specifications subject to change without notice. Photos and diagrams in this brochure are for promotional purposes only. Refer to appropriate UpRight Operator's manual for detailed instructions on the proper use and maintenance of this equipment.

standard features

- Proportional one-hand control
- Large platform
- Fully automatic on-board charger
- 24V DC motor and 220 Ah batteries
- Hydraulic (TL49) or Quickset™ manual (TL38) outriggers
- Outrigger interlocks and warning alarm
- Energy-efficient motor control system
- Tilt alarm (Hydraulic Outriggers)
- Line contactor system for AC operation
- Outrigger safety interlocks and warning lights
- Cycle guards
- 1 year parts/service
- 5 year structural warranty

options

- Power line to platform
- Hour meter
- Flashing beacon
- Fibreglass platform
- Spare tire kit
- Drive assist (TL49)
- Generator pack
- Hydraulic or manual outriggers (TL38)
- Special paint colors
- Environmental green oil

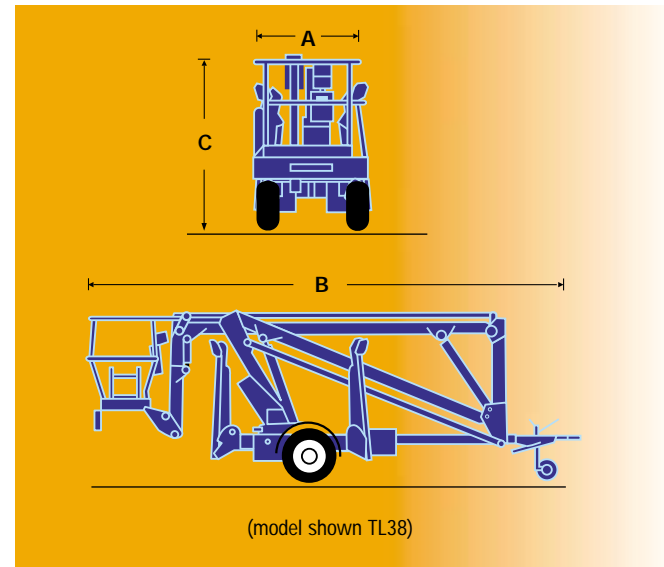
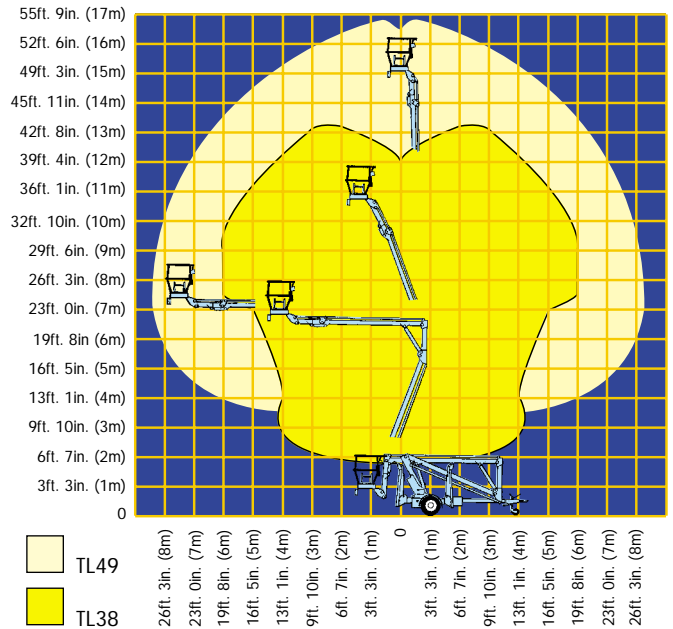

Meets or exceeds applicable requirements of OSHA and ANSI A92.2 - 1999.

CE This product is available with the CE mark confirming compliance with all relevant European Machinery Directives

manufactured by
UpRight

UpRight

www.upright.com
e-mail: marketing@upright.com

GLOBAL PROVIDER OF ACCESS SOLUTIONS

MANUFACTURING

North America
Tel + 1 (559) 662 3900
Fax + 1 (559) 673 6184

Europe
Tel + 353 1 620 9300
Fax + 353 1 620 9301

SALES

USA / The Americas
Tel + 1 (559) 662 3900
Fax + 1 (559) 673 6184

Europe/Africa/M. East
Tel + 44 (0) 1952 685 200
Fax + 44 (0) 1952 685 255

France
Tel + 33 130 37 05 44
Fax + 33 130 37 63 68

Germany
Tel + 49 2103 98950
Fax + 49 2103 989549

Singapore
Tel + 65 6324 1322
Fax + 65 6225 5157

Australia
Tel + 61 2 9748 6200
Fax + 61 2 9748 6255

P. R. China
Tel + 86 21 63390190
Fax + 86 21 63390191

Japan
Tel + 81 3 5765 6841
Fax + 81 3 5765 6840